

The Sentinel - Overview

DIMENSIONS (mm)

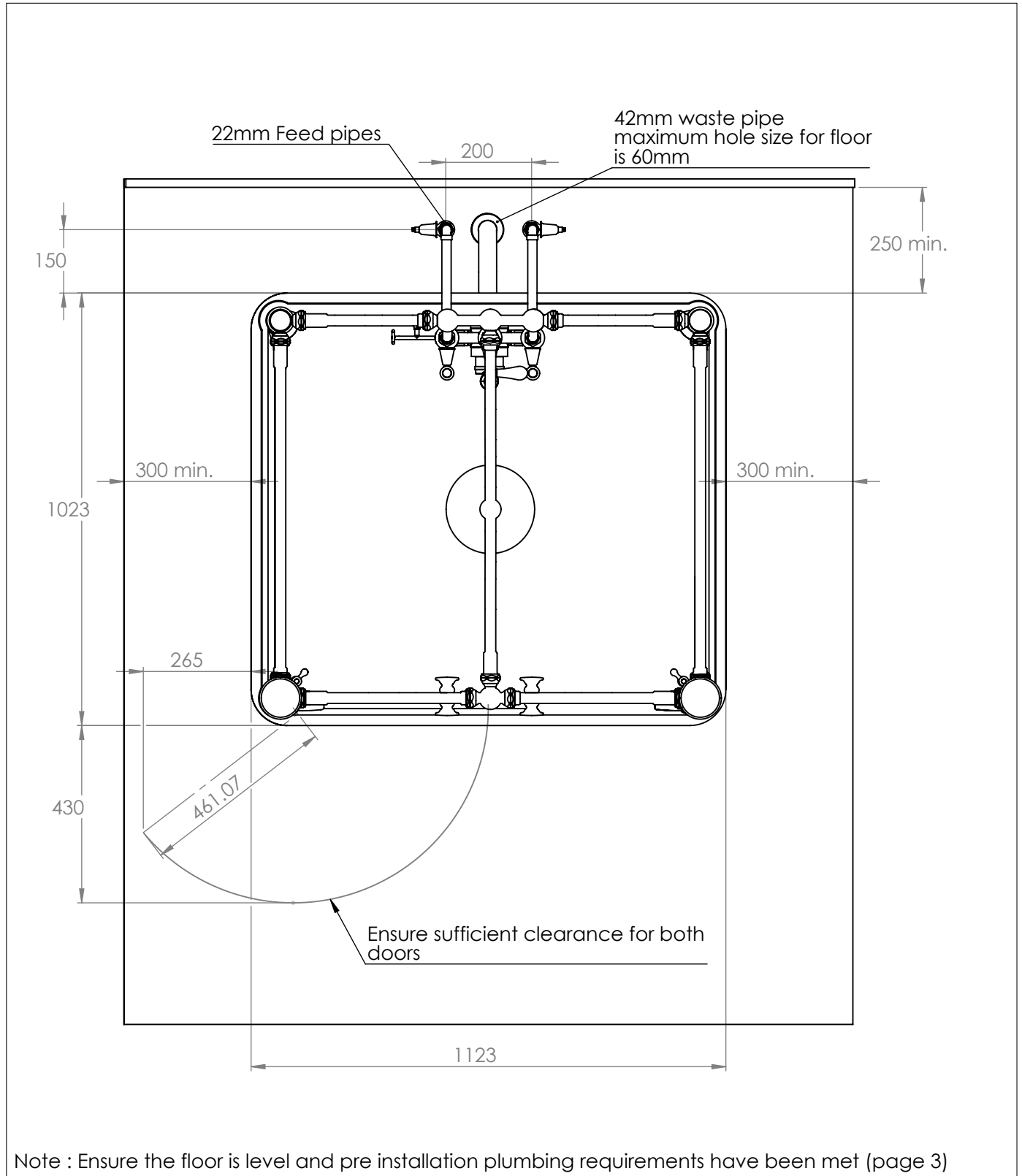

PLEASE NOTE: Whilst every effort is made to ensure the accuracy of these specification sheets, they are subject to change without notice as part of the company's ongoing product development process.



The Sentinel - Overall Dimensions

DIMENSIONS (mm)

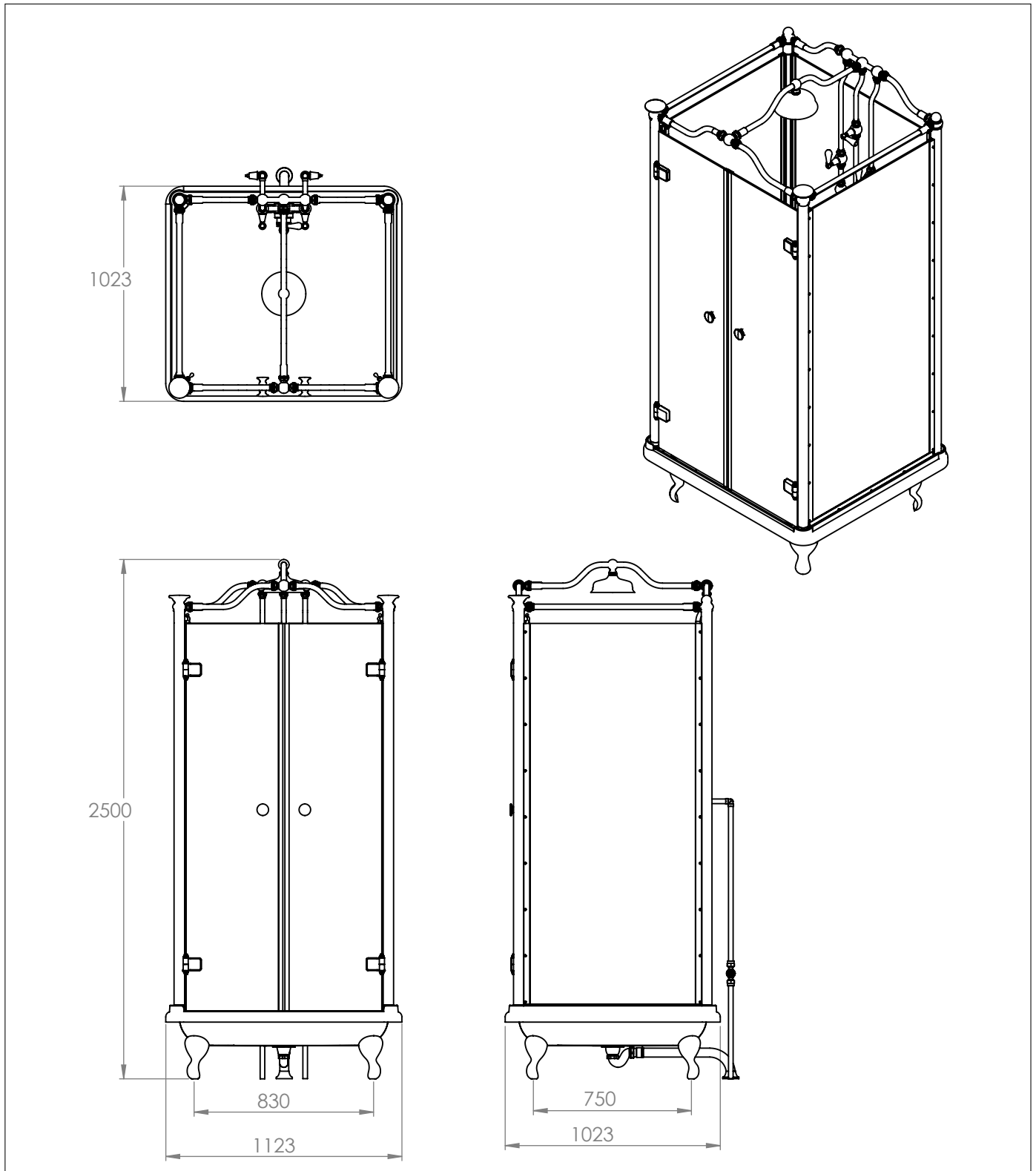

PLEASE NOTE: Whilst every effort is made to ensure the accuracy of these specification sheets, they are subject to change without notice as part of the company's ongoing product development process.



The Sentinel - Plumbing Requirements

DIMENSIONS (mm)

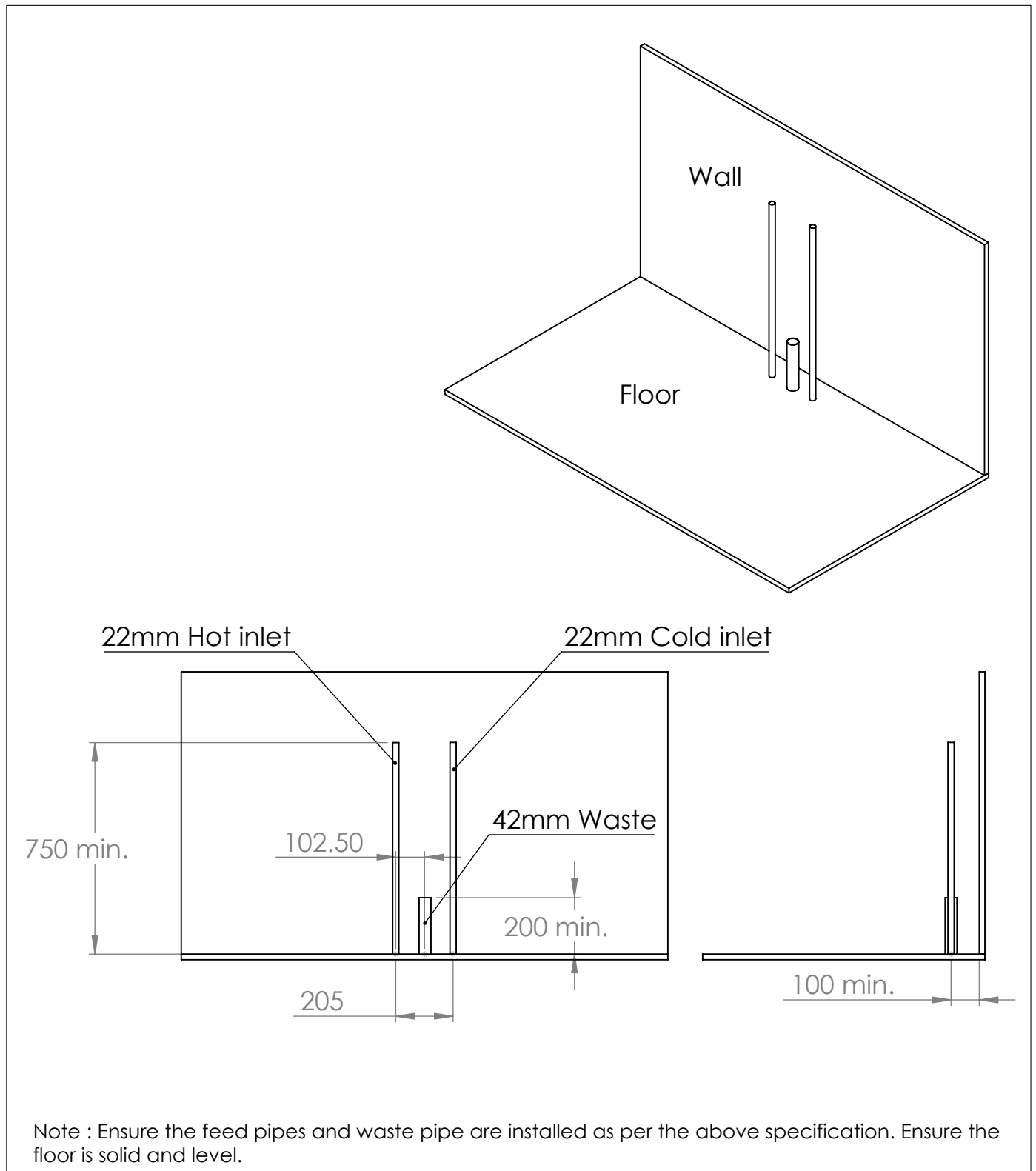

PLEASE NOTE: Whilst every effort is made to ensure the accuracy of these specification sheets, they are subject to change without notice as part of the company's ongoing product development process.

