

The Original Wall Mounted Towel Rail (Dual Fuel)

DIMENSIONS (mm)

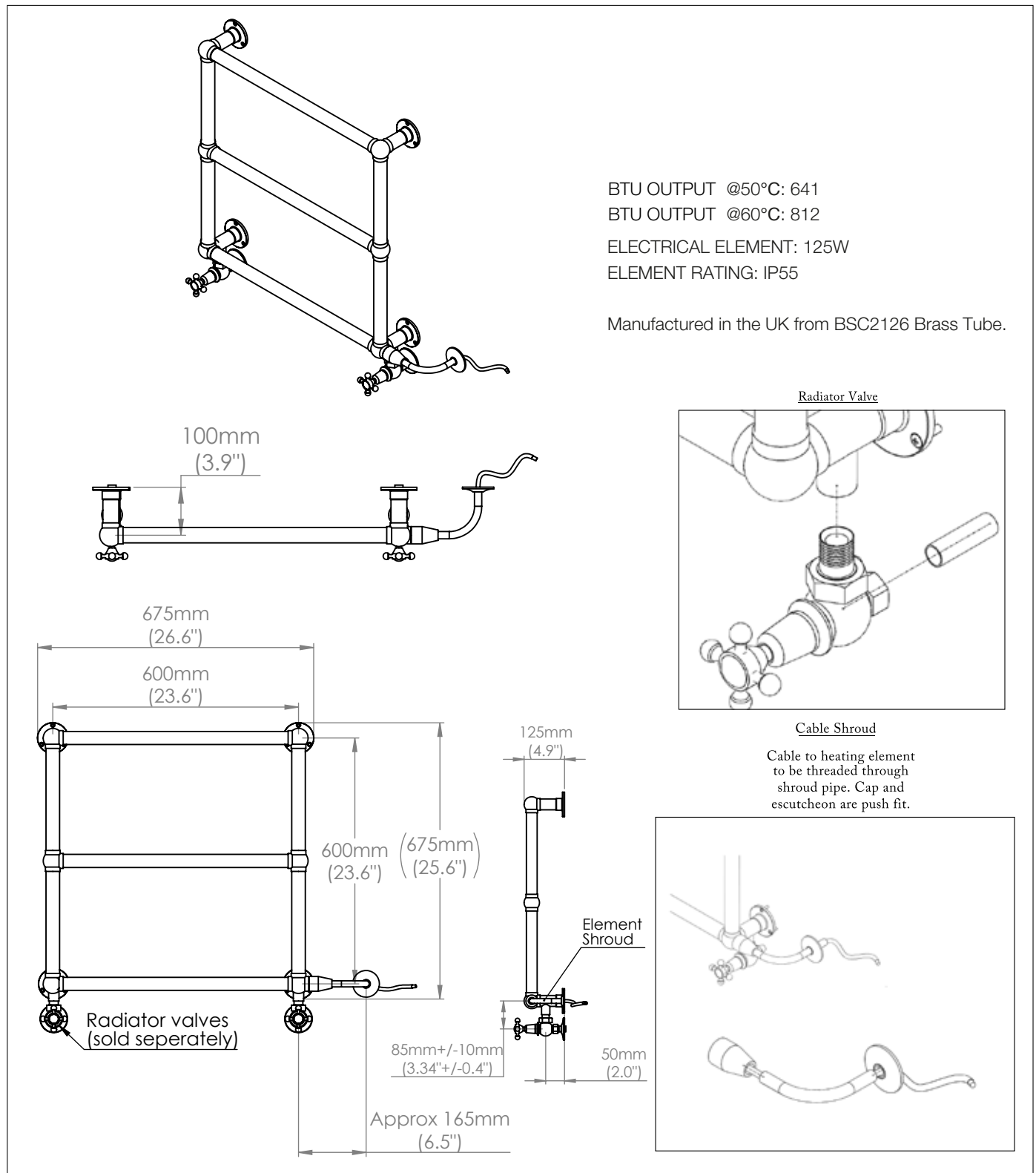

PLEASE NOTE: Whilst every effort is made to ensure the accuracy of these specification sheets, they are subject to change without notice as part of the company's ongoing product development process.

