

La Parisienne Double Vanity Unit

DIMENSIONS (mm)

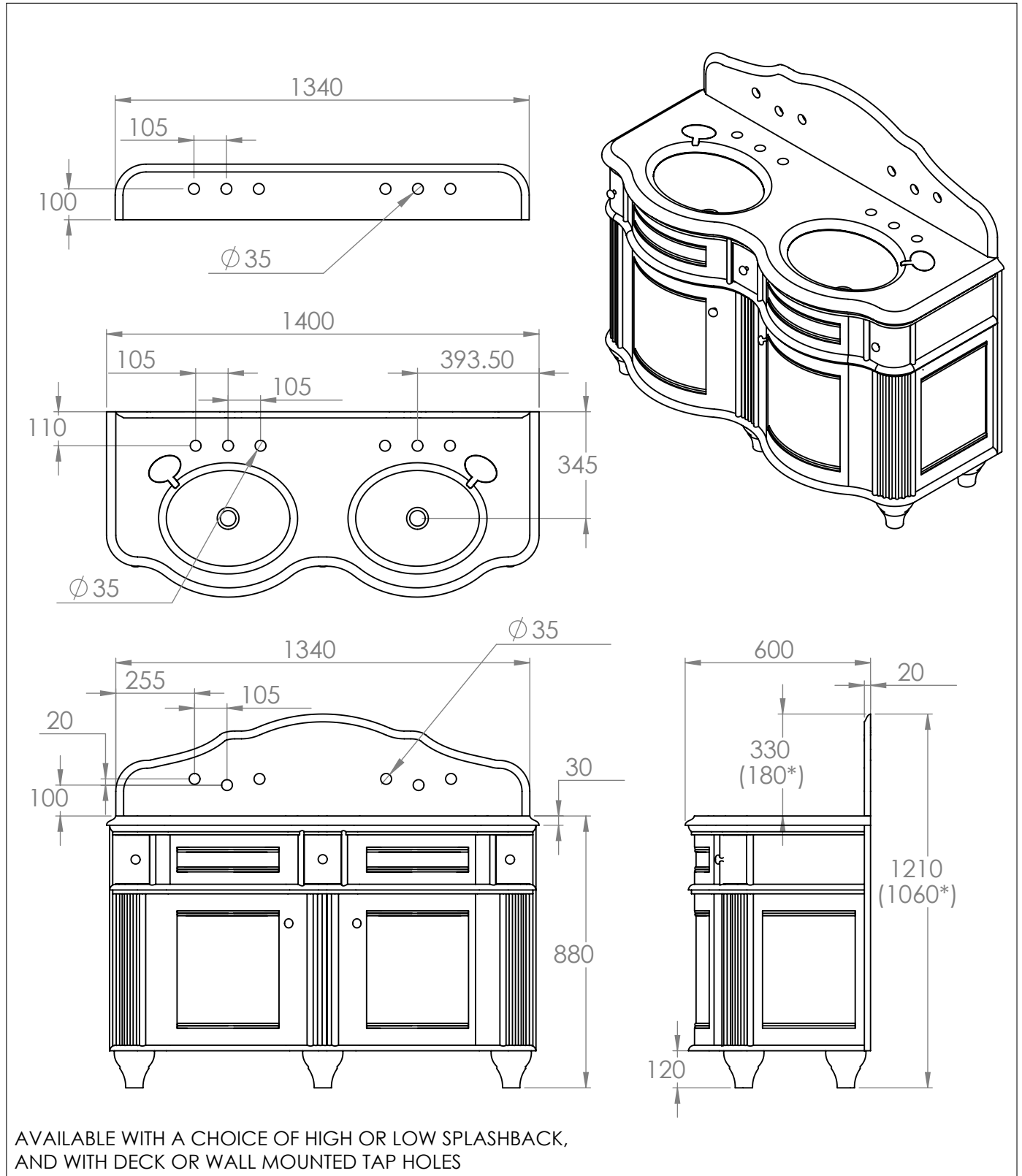

AVAILABLE WITH A CHOICE OF HIGH OR LOW SPLASHBACK,
AND WITH DECK OR WALL MOUNTED TAP HOLES

PLEASE NOTE: Whilst every effort is made to ensure the accuracy of these specification sheets, they are subject to change without notice as part of the company's ongoing product development process.

