

The Original Arched Ladder Heated Towel Radiator

STANDARD, DUAL FUEL & ELECTRIC MODELS

Our classic shape, manufactured in Great Britain from the highest quality brass. The Original Arched Ladder heated towel radiator presents a simplicity of design and class with its timeless, tubular structure and detailed finish. The Original Collection of heated bathroom towel rail is presented in a variety of options and finishes to suit your requirements including Aged Brass, Aged Copper, Chromium Plate, Black Nickel and more. Elegant and functional, they can be manufactured to operate as:

Standard – for central heating systems.

Electric – fitted with an electric element.

Dual Fuel – suitable for use with both central systems and electric controls.

IMPERIAL DIMENSIONS (IN)	METRIC DIMENSIONS (MM)	BTU RATING	
		@50°C	@60°C
46.3H x 26.6W x 10.8D	1175H x 675W x 275D	1604	2030

DUAL FUEL EXAMPLE

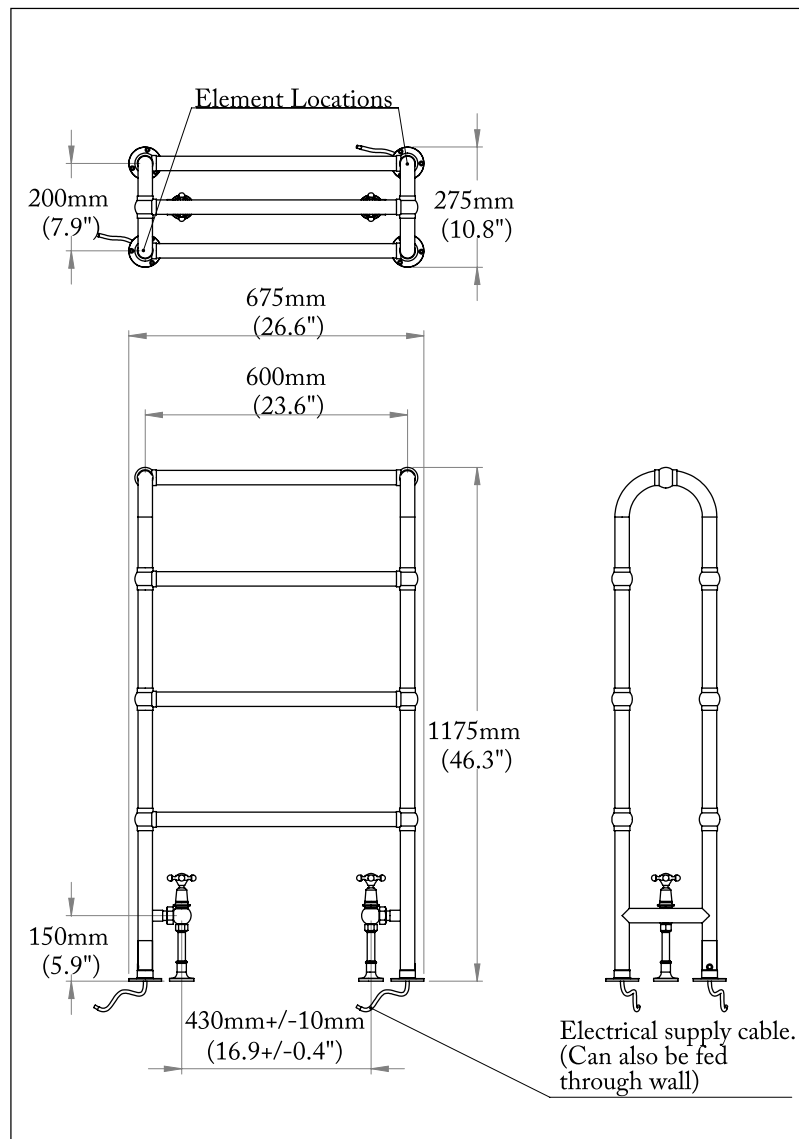

RADIATOR VALVES (Sold Separately)

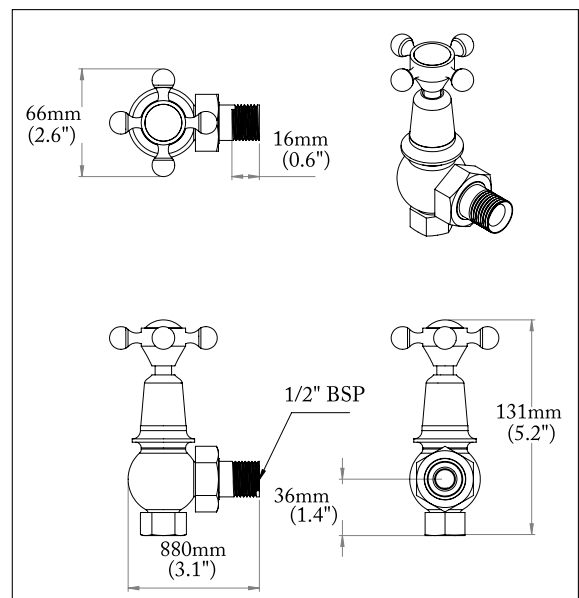

The Original Arched Ladder Heated Towel Radiator

STANDARD, DUAL FUEL & ELECTRIC MODELS

STANDARD FINISHES

POLISHED BRASS

Buffed and burnished to a high golden sheen, Polished Brass is a living finish that will naturally develop a darker hue.



SILVER NICKEL

Silver Nickel is the original plated finish introduced in the late nineteenth century. It resembles a solid silver with warm tones and a golden hue.



CHROME PLATE

Used extensively on today's modern fittings, the highly polished and durable finish is silver with a hint of blue undertone.



PREMIUM FINISHES

BRUSHED BRASS

Pure brass that has been lightly abraded by hand to achieve a matt golden finish.



BRUSHED NICKEL

A steely silver finish. Its matt appearance generates an industrial feel and allows it to site well within minimal and contemporary settings.



BRUSHED CHROME

A more modern blue-silver finish. Dull and steely this finish is also suitable for contemporary settings.



AGED BRASS

Pure brass that has been treated to accelerate the process of oxidation generating a dark and warm living bronze finish.



BLACK NICKEL

A burnt nickel appearance, resembling the colour of pewter. This minimal finish sits equally well in both contemporary or rustic settings.



AGED COPPER

With its rich russet tones, this finish is particularly suited to traditional properties or an industrial style interior.



RADIATOR VALVES

We manufacture our radiator valves in two styles - The English and La Loire. Both of which are available in our full range of finishes.

